



Hydromantis, Inc.

ARTSTM

A Quick Introduction to ARTS

Hydraulic analysis/design
software package for water and
wastewater treatment systems

Design Upgrades Process Audits
Assessment CSO

Copyright © 2003 Aquavarra Research Limited. All rights reserved.

No part of this work covered by copyright may be reproduced in any form or by any means - graphic, electronic or mechanical, including photocopying, recording, taping, or storage in an information retrieval system - without the prior written permission of the copyright owner.

The information contained within this document is subject to change without notice. Aquavarra Research Limited makes no warranty of any kind with regard to this material, including, but not limited to, the implied warranties of merchantability and fitness for a particular purpose. Aquavarra Research Limited shall not be liable for errors contained herein or for incidental consequential damages in connection with the furnishing, performance, or use of this material.

Trademarks

ARTS and all other Aquavarra Research Limited trademarks and logos mentioned and/or displayed are trademarks of Aquavarra Research Limited.

Adobe and Acrobat are trademarks of Adobe Systems Incorporated. Microsoft, Windows, Window NT, Windows 98, Windows 2000, Windows ME and Windows XP are trademarks of the Microsoft Corporation.

All other products or services mentioned in this document are identified by the trademarks, service marks, or product names as designated by the companies who market those products. Inquiries concerning such trademarks should be made directly to those companies.

Printing Date: October 2003

Hydromantis, Inc.
1685 Main Street West, Suite 302
Hamilton, Ontario, Canada L8S 1G5

Tel: +1 905 522 0012
Fax: +1 905 522 0031
info@hydromantis.com
www.hydromantis.com



Introducing GPS-X

Welcome to ARTS, an hydraulic analysis/design software package, developed with the needs of water and wastewater engineers in mind. It spans the spectrum of hydraulic problems encountered in water and wastewater engineering as well as incorporating specific features related to the hydraulic design of wastewater treatment systems. It is operated through a user-friendly graphical interface, which will enable you to sketch an outline representation of the hydraulic system under consideration. The software then interprets this sketch in order to return a solution to the problem at hand.

This demonstration version of ARTS gives you all the features of the full versions of ARTS for 30 days. The only limitation is that file saving and printing functions have been disabled. Before the 30-day point you can purchase ARTS and turn the demo into permanent license. You do this by selecting File/Register and sending us the displayed information. Using this data we will then generate a permanent keycode that you can enter in the File/Register dialog box. If you go past the 30-day point and wish to install a full version, you need to first uninstall the ARTS demo. Do this using the normal Windows method from Start -Settings - Control Panel - Add/Remove Programs - [highlight] ARTS32 [and click the] Add/Remove [button].

The operational features of the user interface are explained in detail in the full manual available in Adobe Acrobat format on your ARTS demonstration CD. A summary of the applied hydraulics, which underpins the ARTS computer coding, is presented in the Appendix of the manual.

System Requirements

ARTS has been designed to run in Windows 95 or later versions and Windows NT 3.51 or later versions and hence you must have the appropriate Windows software installed on your PC before you can install and use ARTS.

The ARTS hardware requirements are the same as required for the Windows interface. The recommended minimum processor hardware specification is:

- Pentium with 24 Mb RAM (rec 32 MB)
- 90 MHz processor
- 20 Mb disk space
- NT 4.0 or higher
- 2 button mouse

Installation

The ARTS demonstration program can only be used when it has been installed on your computer's hard disk. The ARTS demonstration program can be installed from the Demonstration CD or downloaded from www.hydrumantis.com.

Install ARTS from a CD

The following procedure describes how to install ARTS directly to your computer's hard disk from the supplied CD ROM. As with any software, before you install the ARTS software on your PC, you should carry out steps 1 to 3.

1. If you have a back up system, make a back up of your PC.
2. If you are using a virus-detection utility, disable it before running Setup. If you do not disable the utility, Setup may conflict with it and not run.
3. Make sure that you close all open applications. This includes applications that run automatically when you start Windows, possibly Microsoft Office or a virus-detection utility.



4. Insert the ARTS DEMONSTRATION CD ROM into your PC.
5. The install procedure should start automatically after a few seconds. If it does not, click on the START button, and choose Run. A dialog box appears as in Figure 0.1.
6. In the **Open:** box, type the letter of the drive that contains the CD ROM, followed by **:** and the word **setup**. For example, type **d:\setup**
7. Choose the OK button, and then follow the instructions on the screen. Setup asks you to close any open applications. If applications are open, and you need more information about how to close them, choose the Help button. To close Help, choose Exit from the File menu in Help.

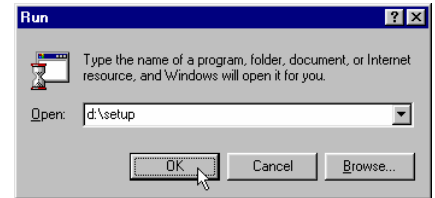

Figure 0.1 The Run Dialog box

ARTS is supplied with an installation procedure which creates a working directory on your hard disk, into which all the ARTS files are transferred.

Click the Next button to continue installation. You will be prompted for some user information and details on how you wish to configure the software installation; however, all the options can be left at their default values.

Install ARTS from Web Site Download

When you completed the on-line form on our web site you will have downloaded a single file to a folder on your PC. The file name will be **ARTSwdemo.exe** and will be about 8 MB in size.

The procedure to install the ARTS demo is as follows:

1. Navigate to the folder where the **ARTSwdemo.exe** file is stored.
2. Double-click the file.
3. A dialog box will appear requesting a password for extracting the files. Enter the password "evalu8".

The files will be extracted and the set-up and installation will proceed automatically. You have the option to change the installation folder.

Where to Start

To begin exploring ARTS, you may want to try some of the automated learning features that come with this demonstration version of ARTS (and with the full version):

- ARTS comes with on-line videos that show you how to use ARTS. These can be found in **My Documents\ARTS** files. There are three video show available: "**Basics**", "**Examples 1-10**", and "**Examples 11-20**". The on-screen video is controlled using a Lotus Screen Cam control panel that will appear on your screen as the videos commences. Placing the mouse over any of the buttons on the Screen Cam control window will bring up a description of the function of that button



- The files for all 20 of the examples shown in the videos have been provided with the demonstration version of arts. Using the **Open** option in the files directory, find the directory "Examples" (if you used the default installation directory, this can be found under C:\Program Files\Aquavarra\Arts\User Files\Examples).

- Four additional samples that highlight some of the functions of ARTS can also be found in the "Samples" directory (if you used the default installation directory, this can be found under C:\Program Files\Aquavarra\Arts\User Files\Samples). These include two wastewater treatment plant examples, a waterhammer example, and a reservoir-pipe network.

Sketching the Layout and Setting Properties

Notes:

- Click means press and release the left-hand mouse button quickly;
- Double-click means press and release the left-hand mouse button twice in quick succession;
- Drag means move the mouse while holding down the left-hand mouse button;

Placing objects on the design sheet

To draw an object on the design sheet:

- Select the desired object type by clicking on its tool button. The selected tool button is depressed and remains so until another tool button is pressed.
- Move the cursor to one of the intended corner positions for the object on the design sheet. The cursor shape should be in the shape of a cross-hair.
- Click and then move the cursor to draw an outline of the object to the required size - the cursor movement traces a dotted outline of the object on the design sheet.
- When the dotted outline is of the required size, click again to place the object on the design sheet.

If the drawn object is a linear element such as a pipe or channel, its terminal points are identified by a pair of small squares, known as selection handles; if it is a process unit such as a tank or pump, its drawn outline space is identified by a set of 4 selection handles when the object is selected.

Selecting objects

To select one object:

- If the selection tool is not already selected, click on the selection tool
- Click on the object you wish to select
- Small black squares appear at the extremities of the selected object to indicate that it is selected



Not selected

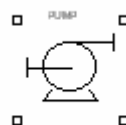

Selected

To select several objects:

- If the selection tool is not already selected, click on the selection tool 
- Drag across the objects you wish to select, enclosing them in the dotted selection rectangle which appears. The starting point of a selection rectangle must not be at the same place as one of the objects on the sheet
- Small black squares appear at the extremities of each of the selected objects to indicate that they are selected

Re-sizing objects

To re-size an object:

- Select the object you wish to resize
- Place the cursor over one of the selection handles, the cursor changes shape to a double-headed arrow
- Drag to re-size

Moving objects

To move an object:

- Select the object or objects that you wish to move
- Place the cursor over the object, a small 4-headed arrow appears to the bottom right of the cursor arrow
- Drag to move to a new location.

Deleting objects

To delete an object:

- Select the object or objects that you wish to delete
- Press the Delete key on the keyboard or
- Choose Delete from the Edit menu

Drawing hydraulic systems

Pipes and channels:

Both pipes and channel convey fluid from one point to another and can both be regarded as links. An individual link is defined by the locations of its end points. Any link that starts or terminates at the end point of another link is considered to be connected to that link. Pipes and channels should start and end either in another object or at the end of another link. If you try connecting links to the very edge of other objects, ARTS may not register the connection.

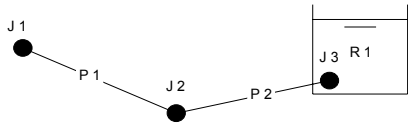

Figure 0.1 Connected pipes

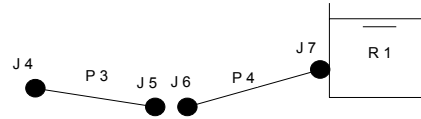

Figure 0.2 Unconnected pipes

Other hydraulic objects:

Treatment process units

These objects should not be placed in other objects. Links are deemed to be connected to a process unit such as a reservoir or biofilter, if one of the link's end points is located within the area enclosed by the outline of the process unit. In **Hydraulic profile** analysis each unit can only have two connections (one in and one out). In **Steady pipe flow** and **Unsteady pipe flow** analysis, reservoirs can have multiple connections.

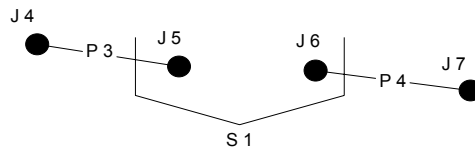

Figure 0.3 One inflow and one outflow pipe

Pumps

ARTS uses the standard graphical representation of a rotodynamic pump, which distinguishes its suction/inflow and delivery/outflow points (the central line represents inflow, the tangential line represents outflow). Basically, think of a pump as having 2 small pipes coming out from it (one on each side) onto which you connect your links.

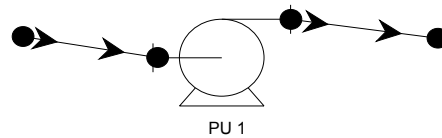

Figure 0.4 Pump with one inflow and one outflow pipe

Supply/demand:

The flow object is used to represent either an inflow/supply or an outflow/demand.

To indicate an inflow/supply at a pipe or channel junction:

- Draw the flow object on the sheet with the arrow pointing towards the junction (start the drawing process at a point away from the junction).

To indicate an outflow/demand at a pipe or channel junction:

- Draw the flow object on the sheet with the arrow pointing towards the junction (first mouse click at the junction).

Note: The flow object can only be used at junctions i.e. it cannot be connected directly to a process unit. All flow objects which are not connected to junctions will be ignored.

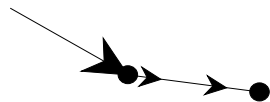

Figure 0.5 Inflow

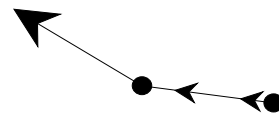

Figure 0.6 Outflow

Exercise

Draw the systems illustrated in Figures 2.7 by using reservoir, pipe and pumps.

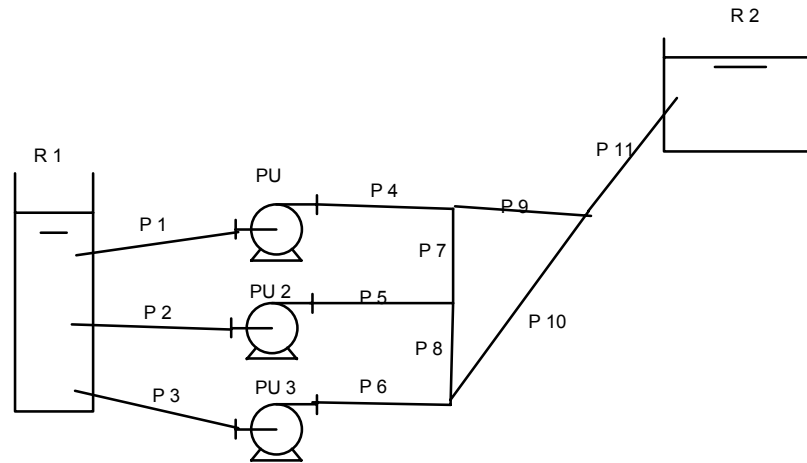

Figure 0.7 Pumping system - system creation exercise

Continuity check

When you have completed your layout sketch of the hydraulic system, you can check that the connectivity of its elements has been correctly interpreted by the software by running the **Compile** command from the **Analysis** menu. On completion of the compilation process, ARTS places a solid circle over each registered junction according to the following colour coding:

1. pipe-to-pipe junctions are represented by a **red** circle
2. a **green** circle is placed at each junction which has registered an inflow or outflow
3. a **blue** solid circle is placed at all other junctions (channel-to-channel, pipe-to-process unit, pipe-to-channel) that have been registered by the compilation process.

A correctly registered system should comply with the foregoing colour coding and each compiled node should be represented by a single solid coloured circular dot.

Deviation from the foregoing requirements at any node indicates that its junction connectivity has not been correctly registered by ARTS i.e. the terminal points of the elements that meet at the junctions are not sufficiently close for ARTS to conclude that they are connected.

Connectivity faults can be corrected by repositioning the objects on the design sheet.

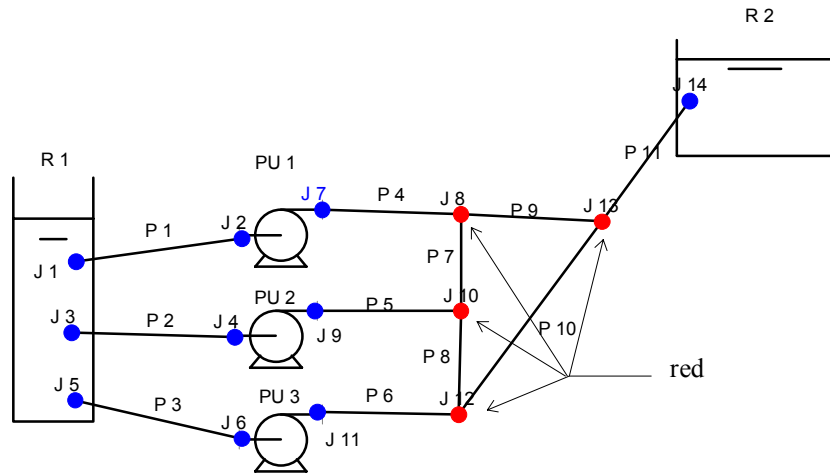

Figure 0.8 Pumping system - Compile exercise (all nodes blue, except marked)

Setting Properties

Every hydraulic object that you place on the design sheet has properties associated with it. These properties are accessible via dialog boxes known as Property Pages. For example, a pipe object has a length property, a diameter property, a surface roughness property etc. When you place an object on the design sheet you are essentially creating a virtual version of a real world object. For example, when you place a pipe on the screen and then display its Property Pages, you will find that the pipe has a value for length, diameter as well as its other properties. You will probably have to change these values in order represent the element of the real world system you are trying to model. Objects that have not had their initial properties changed are drawn in grey on the design sheet.

To access the properties of any object,

- select the object and then,
- press the properties tool button on the tool palette.

Alternatively, click on the object with the RIGHT mouse button. A menu should appear over the object. Select Properties from this menu. The Property Pages for every object have a similar layout. The Property pages for pipe objects are displayed in Figure 0.9.

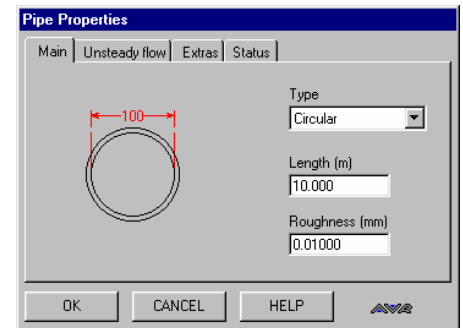

Figure 0.9 Pipe property pages

Changing Units of Measure

SI is the default units system in this ARTS demonstration. To change the default units system:

- Select **Options** under the **Tools** menu at the top of ARTS
- Set the units default by selecting the corresponding units system

Alternatively, you may change the units for specific data entries. Point to the units indicator (e.g., over (m) beside the word Length in Figure 2.9) and then click. You will be given a list of viable units to choose. Select the appropriate unit.

Performing System Analysis

All objects can be used individually to design an individual object. Not all the objects can be used with all the analysis functions. For example, Air Vessels can only be used in Unsteady pipe flow analysis and will be ignored by the other analysis functions.

Exercise 1

Calculate the headloss in a pipe, having an ID of 605mm and a surface roughness of 0.06mm, at a flow of 0.3m³/s. The pipe length is 3,459m and it includes four 90° short-radius bends.

Step 1

Draw a pipe on the design sheet (the pipe will be grey until you set some of it's properties)



Step 2

Edit the Length, Roughness, and Diameter on the **Main** property page:

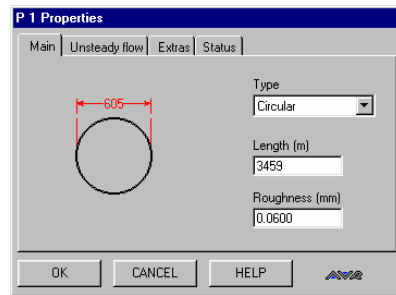

Step 3

- a) Add the 90° bends on the **Extras** page from the drop down boxes for the Fitting type.
- b) Enter the Chainage and Elevation. Hit the **Add** button as each fitting definition is completed:

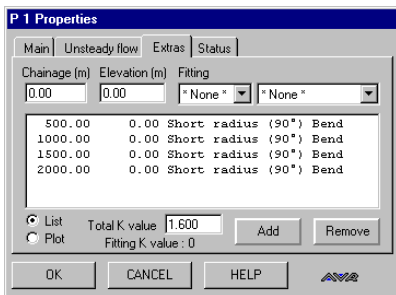

Step 4

Click on the **Status** page

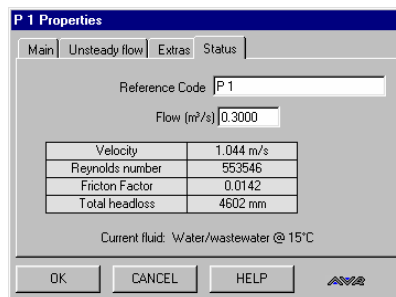

Solution: The headloss through this pipe is **4.6m** at **0.3m³/s**.

Exercise 2

An old rising main is 6580m long and has an internal diameter of 345mm. Under normal steady state operational conditions, the flow has been measured at 100 l/s and the corresponding headloss has been measured at 19.5m. Compute the effective pipe wall roughness.

Step 1

Draw a pipe on the design sheet (the pipe will be grey until you set some of it's properties)



Step 2

Edit the **Main** property page:

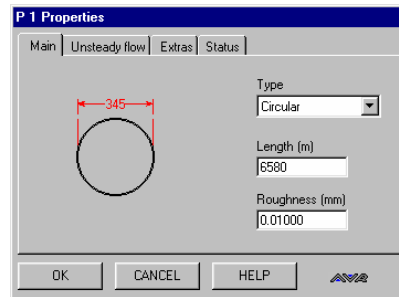

Step 3

Click on the pipe calculator tool



Step 4

Set the parameters (you will need to change the units for Flow and Headloss) on the pipe calculator dialog and press "k value"

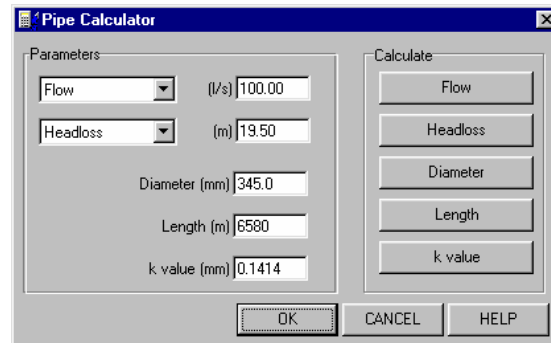

Solution: The effective k value is **0.1414mm**.

Exercise 3

- Construct a pipe system similar to that shown on Figure 0.1 on your design sheet. Figure 0.1 shows a trunk and branch pipe system, as it would appear on the design sheet after compilation; it includes five pipe elements, 3 demands, an upstream reservoir plus an additional supply.

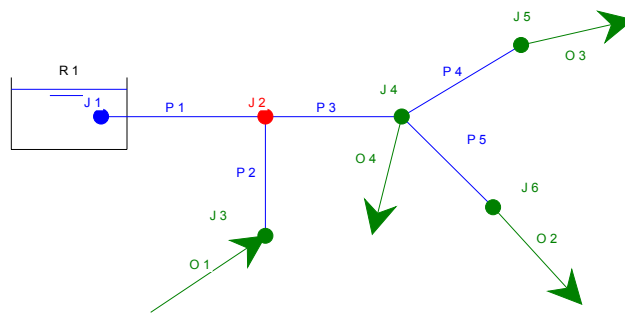

Figure 0.1 Network system

- click on the **Compile** command in the **Analysis** menu; the pipe system nodes are now highlighted by coloured circles (pipe-to-pipe junctions are red, inflow/outflow nodes are green, all other nodes are blue). Note that each pipe junction should be represented by a single coloured circle. If there are two coloured circles at a pipe junction, or the colour coding is not correct, the junction is not correctly registered by ARTS and a correction must be made (Chapter 3).
- select each pipe element in turn (first click the selection tool and then click the drawn pipe element) and edit its values for diameter, length and surface roughness, using the property pages so that each pipe is 100m long, with a surface roughness of 0.01mm and a diameter of 100mm.
- select each supply and demand in turn and edit its value; edit the current flow value to $0.01\text{m}^3/\text{s}$.
- Click on the **Steady Pipe Flow** command on the **Analysis** menu to compute flow and pressure distribution. The computed flow and head values are printed on the design sheet, as are the flow directions, as shown in Figure 0.2.

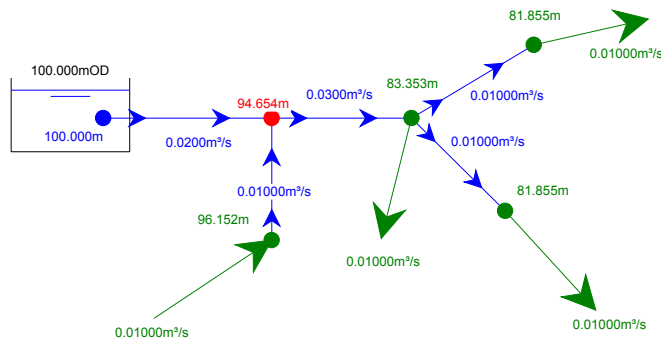

Figure 0.2 Solved Network system

Exercise 4

- Draw the system shown on Figure 3.3 on your design sheet

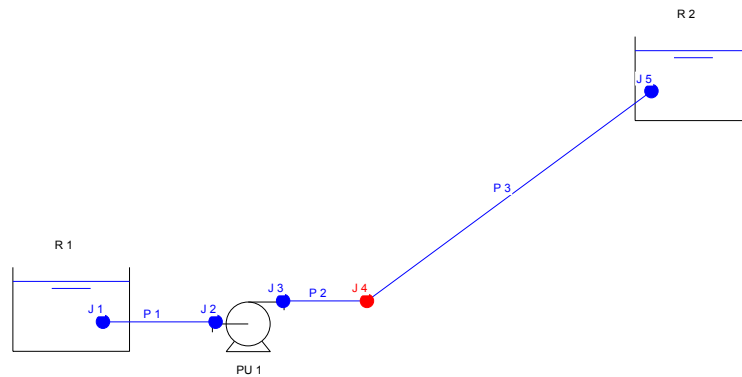

Figure 3.3 Pump system

- compile your system (**Compile** command on the **Analysis** menu) and make any corrections necessary.
- make the following changes to the system values:
- reservoirs**: change the downstream reservoir level (R2 in Figure 3.3) to 200.00m (check that the upstream sump level is 100.00 m)
- suction pipe** (P1 in Figure 3.3): use the **Extras** page of its property box to add a 90° elbow bend at 5m Chainage.
- delivery pipe** (P2 in Figure 3.3): use the **Extras** page of its property box to add a non-return valve (at 2 m Chainage), a gate valve (at 5 m Chainage) and a 90° elbow bend (at 8 m Chainage).
- rising main** (P3 in Figure 3.3): set its length as 500m and internal diameter to 200mm.
- use the **Steady Pipe Flow** command on the **Analysis** menu to compute the pump duty point
- check the duty point head, efficiency and required NPSH by entering the duty flow in the flow text box on the **Status** property page for the pump.

Exercise 5

Calculate the normal depth in a concrete U-shaped channel, which has a base width of 1500mm, a gradient of 1 to 1500 and is used to convey sewage at a flow rate of flow 1.65m³/s

Step 1

Draw a channel on the design sheet (the channel will be grey until you set some of its properties)

Step 2

Edit the **Main** property page by changing the depth and width of the channel:

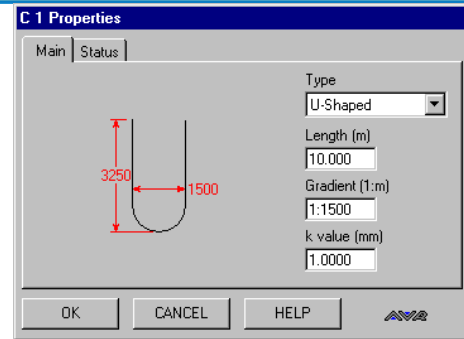

Step 3

Click on the **Status** page and change the flow to 1.65m³/s.

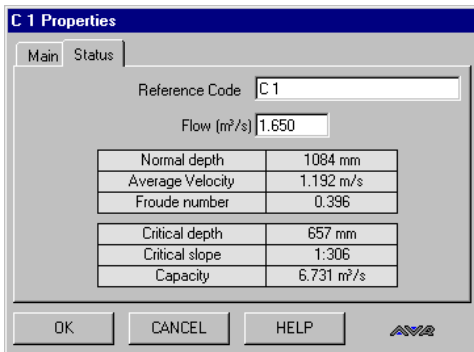

Solution: The normal depth is **1085mm** at **1.65m³/s**.

Exercise 6

Determine the water surface profile in a parabolic channel with the following properties:

length (m)	25
width (mm)	2000
height (mm)	1500
k-value (mm)	1
bottom slope	1:1200
end inflow (m ³ /s)	1.5
lateral inflow (m ³ /s)	0.1
outlet end control depth (mm)	850

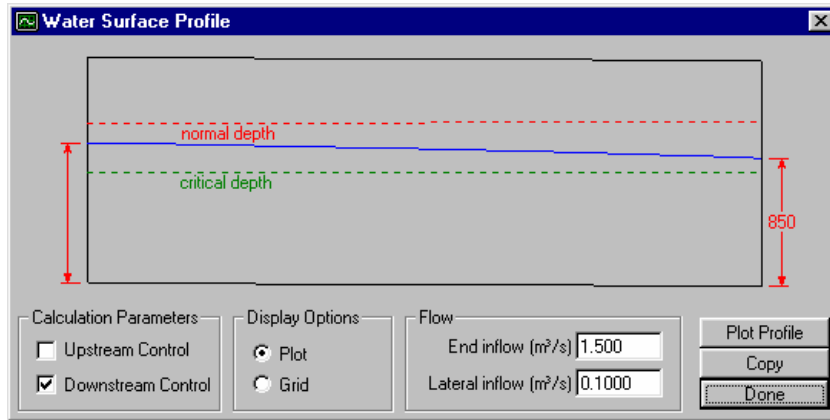

Figure 3.4 Plot from exercise 6

Closure

The exercises in this Demonstration Manual touch on a small fraction of the analyses that can be conducted with ARTS. For more complex examples of open channel flow systems, wastewater treatment plants, and waterhammer analyses, please see the examples available in the HELP menu (Select the **Help Topics** in the **Help** menu. Go to the **Content** tab and double click on Examples.).